



**INTERCONNECTION  
FACILITIES STUDY  
REPORT**

GEN-2019-039

Published February 2025

By SPP Generator Interconnections Dept.

## REVISION HISTORY

---

DATE OR VERSION NUMBER	AUTHOR	CHANGE DESCRIPTION
February 7, 2025	SPP	Initial draft report issued.
February 27, 2025	SPP	Final report posted.

# CONTENTS

---

Revision History .....	i
Summary .....	1
Introduction .....	1
Phase(s) of Interconnection Service .....	1
Compensation for Amounts Advanced for Network Upgrade(s).....	1
Interconnection Customer Interconnection Facilities .....	2
Transmission Owner Interconnection Facilities and Non-Shared Network Upgrade(s) .....	3
Shared Network Upgrade(s) .....	5
Contingent Network Upgrade(s).....	6
Affected System Upgrade(s) .....	7
Conclusion.....	8
Appendices .....	9
A: Transmission Owner’s Interconnection Facilities Study Report and Network Upgrades Report(s)...	10

## SUMMARY

---

### INTRODUCTION

This Interconnection Facilities Study (IFS) for Interconnection Request GEN-2019-039 is for a 174.5 MW generating facility located in Butler, NE. The Interconnection Request was studied in the DISIS-2018-002/DISIS-2019-001 Impact Study for ER/NR. The Interconnection Customer's requested in-service date is February 5, 2027.

The interconnecting Transmission Owner, Nebraska Public Power District (NPPD), performed a detailed IFS at the request of SPP. The full report is included in Appendix A. SPP has determined that full Interconnection Service will be available after the assigned Transmission Owner Interconnection Facilities (TOIF), Non-Shared Network Upgrades, Shared Network Upgrades, Contingent Network Upgrades, and Affected System Upgrades that are required for full interconnection service are completed.

The primary objective of the IFS is to identify necessary Transmission Owner Interconnection Facilities, Network Upgrades, other direct assigned upgrades, cost estimates, and associated upgrade lead times needed to grant the requested Interconnection Service.

### PHASE(S) OF INTERCONNECTION SERVICE

It is not expected that Interconnection Service will occur in phases. However, full Interconnection Service will not be available until all Interconnection Facilities and Network Upgrade(s) can be placed in service.

### COMPENSATION FOR AMOUNTS ADVANCED FOR NETWORK UPGRADE(S)

FERC Order ER20-1687-000 eliminated the use of Attachment Z2 revenue crediting as an option for compensation. The Incremental Long Term Congestion Right (ILTCR) process will be the sole process to compensate upgrade sponsors as of July 1st, 2020.

## **INTERCONNECTION CUSTOMER INTERCONNECTION FACILITIES**

The Generating Facility is proposed to consist of two hundred forty-six (246) TMEIC NinjaVU\_L0840GR-2 0.81 MW solar inverters for a total generating nameplate capacity of 174.5 MW.

The Interconnection Customer's Interconnection Facilities to be designed, procured, constructed, installed, maintained, and owned by the Interconnection Customer at its sole expense include:

- 34.5 kV underground cable collection circuits;
- 34.5 kV to 115 kV transformation substation with associated 34.5 kV and 115 kV switchgear;
- One 115/34.5 kV 144/192/240 MVA (ONAN/ONAF/ONAF) step-up transformer to be owned and maintained by the Interconnection Customer at the Interconnection Customer's substation;
- An Approximately 0.95 mile overhead 115 kV line to connect the Interconnection Customer's substation to the Point of Interconnection ("POI") at the 115 kV bus at existing Transmission Owner substation ("Columbus Southeast-Rising City 115kV") that is owned and maintained by Transmission Owner;
- All transmission facilities required to connect the Interconnection Customer's substation to the POI;
- Equipment at the Interconnection Customer's substation necessary to maintain a composite power delivery at continuous rated power output at the high-side of the generator substation at a power factor within the range of 95% lagging and 95% leading in accordance with Federal Energy Regulatory Commission (FERC) Order 827. The Interconnection Customer may use inverter manufacturing options for providing reactive power under no/reduced generation conditions. The Interconnection Customer will be required to provide documentation and design specifications demonstrating how the requirements are met; and,
- All necessary relay, protection, control and communication systems required to protect Interconnection Customer's Interconnection Facilities and Generating Facilities and coordinate with Transmission Owner's relay, protection, control and communication systems.

**TRANSMISSION OWNER INTERCONNECTION FACILITIES AND NON-SHARED NETWORK UPGRADE(S)**

To facilitate interconnection, the interconnecting Transmission Owner will perform work as shown below necessary for the acceptance of the Interconnection Customer’s Interconnection Facilities.

**Table 1** and **Table 2** list the Interconnection Customer’s estimated cost responsibility for Transmission Owner Interconnection Facilities (TOIF) and Non-Shared Network Upgrade(s) and provides an estimated lead time for completion of construction. The estimated lead time begins when the Generator Interconnection Agreement has been fully executed.

*Table 1: Transmission Owner Interconnection Facilities (TOIF)*

<b>Transmission Owner Interconnection Facilities (TOIF)</b>	<b>Total Cost Estimate (\$)</b>	<b>Allocated Percent (%)</b>	<b>Allocated Cost Estimate (\$)</b>
<u>Transmission Owner’s Columbus Southeast - Rising City 115kV GEN-2019-039 Interconnection (TOIF) (NPPD) (UID 156684): Facilitate the interconnection of GEN-2019-039</u> Estimated Lead Time: 36 Months	\$700,000	100.00%	\$700,000
<b>Total</b>	<b>\$700,000</b>		<b>\$700,000</b>

*Table 2: Non-Shared Network Upgrade(s)*

<b>Non-Shared Network Upgrades Description</b>	<b>ILTCR</b>	<b>Total Cost Estimate (\$)</b>	<b>Allocated Percent (%)</b>	<b>Allocated Cost Estimate (\$)</b>
<u>Transmission Owner’s Columbus Southeast - Rising City 115kV GEN-2019-039 Interconnection (Non-shared NU) (NPPD) (UID 156685): Facilitate the interconnection of GEN-2019-039</u> Estimated Lead Time: 36 Months	Ineligible	\$7,100,000	100%	\$7,100,000
<u>Transmission Owner’s Rebuild Columbus SE to G19-039-TAP 115 kV (UID 158601): Rebuild approximately 6.76 miles of 115kV line from Clumbus southeast to G16-039-TAP. Estimated Lead Time: 36 Months</u>	Eligible	\$4,000,000	100%	\$4,000,000

Non-Shared Network Upgrades Description	ILTCR	Total Cost Estimate (\$)	Allocated Percent (%)	Allocated Cost Estimate (\$)
<u>Transmission Owner's Rebuild Rising to G19-039-TAP 115 kV (UID 158603): Rebuild approximately 6.76 miles of 115kV line from Rising to G19-039-TAP. Estimated Lead Time: 36 Months</u>	Eligible	\$5,500,000	100%	\$5,500,000
<u>*Transmission Owner's Columbus 115 kV Breaker Replacement (GEN-2019-039) (UID 170557): Replace Columbus Hydro 115 kV Breaker to achieve a minimum rating of 40 KA. Estimated Lead Time: 36 Months</u>	Eligible	\$1,000,000	100%	\$1,000,000
<b>Total</b>		<b>\$17,600,000</b>		<b>\$17,600,000</b>

\*Necessary upgrade identified during Facilities Studies compliant with standards set forth in the SPP Business Practice 7250 as described below:

#### 4.3.3.2 DISIS PHASE 2 SHORT-CIRCUIT FAULT CURRENT CALCULATION

Because sequence data in stability models is not comprehensive, SPP calculates three-phase fault currents for each bus using the models described in section 4.3.1.1 of this Business Practice. Transmission Owners review the results and may identify preliminary issues to SPP along with preliminary upgrades for inclusion in the report. The short circuit analysis assumes that all upgrades identified in the powerflow analysis are in-service unless otherwise noted in the individual group short-circuit results.

Preliminary results are refined in the Interconnection Facilities Study with any additional required upgrades and cost assignment identified at that time.

**SHARED NETWORK UPGRADE(S)**

The Interconnection Customer’s share of costs for Shared Network Upgrades is estimated in **Table 3** below.

*Table 3: Interconnection Customer Shared Network Upgrade(s)*

Shared Network Upgrades Description	ILTCR	Total Cost Estimate (\$)	Allocated Percent (%)	Allocated Cost Estimate (\$)
<u>NA</u>				
<b>Total</b>		<b>\$0</b>		<b>\$0</b>

All studies have been conducted assuming that higher-queued Interconnection Request(s) and the associated Network Upgrade(s) will be placed into service. If higher-queued Interconnection Request(s) withdraw from the queue, suspend or terminate service, the Interconnection Customer’s share of costs may be revised. Restudies, conducted at the customer’s expense, will determine the Interconnection Customer’s revised allocation of Shared Network Upgrades.



**CONTINGENT NETWORK UPGRADE(S)**

Certain Contingent Network Upgrades are **currently not the cost responsibility** of the Interconnection Customer but will be required for full Interconnection Service.

*Table 4: Interconnection Customer Contingent Network Upgrade(s)*

<b>Contingent Network Upgrade(s) Description</b>	<b>Current Cost Assignment</b>	<b>Estimated In-Service Date</b>
NA		

Depending upon the status of higher- or equally-queued customers, the Interconnection Request’s in-service date is at risk of being delayed or Interconnection Service is at risk of being reduced until the in-service date of these Contingent Network Upgrades.

**AFFECTED SYSTEM UPGRADE(S)**

To facilitate interconnection, the Affected System Transmission Owner will be required to perform the facilities study work as shown below necessary for the acceptance of the Interconnection Customer’s Interconnection Facilities. **Table 5** displays the current impact study costs provided by either MISO or AECI as part of the Affected System Impact review. The Affected System facilities study could provide revised costs and will provide each Interconnection Customer’s allocation responsibilities for the upgrades.

*Table 5: Interconnection Customer Affected System Upgrade(s)*

<b>Affected System Upgrades Description</b>	<b>Total Cost Estimate (\$)</b>	<b>Allocated Percent (%)</b>	<b>Allocated Cost Estimate (\$)</b>
NA			
<b>Total</b>	<b>\$0</b>		<b>\$0</b>

## CONCLUSION

After all Interconnection Facilities and Network Upgrades have been placed into service, Interconnection Service for 174.5 MW can be granted. Full Interconnection Service will be delayed until the TOIF, Non-Shared NU, Shared NU, Contingent NU, Affected System Upgrades that are required for full interconnection service are completed. The Interconnection Customer's estimated cost responsibility for full interconnection service is summarized in the table below.

*Table 6: Cost Summary*

<b>Description</b>	<b>Allocated Cost Estimate</b>
Transmission Owner Interconnection Facilities Upgrade(s)	\$700,000
Non-Shared Network Upgrade(s)	\$17,600,000
Shared Network Upgrade(s)	\$0
Affected System Upgrade(s)	\$0
<b>Total</b>	<b>\$18,300,000</b>

Use the following link for Quarterly Updates on upgrades from this report: <https://spp.org/spp-documents-filings/?id=18641>

A draft Generator Interconnection Agreement will be provided to the Interconnection Customer consistent with the final results of this IFS report. The Transmission Owner and Interconnection Customer will have 60 days to negotiate the terms of the GIA consistent with the SPP Open Access Transmission Tariff (OATT).

# APPENDICES

---

**A: TRANSMISSION OWNER'S INTERCONNECTION FACILITIES STUDY  
REPORT AND NETWORK UPGRADES REPORT(S)**

See next page for the Transmission Owner's Interconnection Facilities Study Report and Network Upgrades Report(s).

**NPPD**  
**DISIS-2018-002 / DISIS-2019-001**  
**FACILITY STUDY**

**JANUARY 2025**

**PREPARED FOR:**  
**SOUTHWEST POWER POOL**

**PREPARED BY:**  
**NEBRASKA PUBLIC POWER DISTRICT**  
**ENERGY DELIVERY**  
**TRANSMISSION ASSET PLANNING**  
**ENGINEERING & ASSET MANAGEMENT**



**Nebraska Public Power District**  
*"Always there when you need us"*



The *NPPD DISIS-2018-002 / DISIS-2019-001 Facility Study* was performed to document the interconnection facilities and network upgrades identified by SPP in Phase 2 of the SPP DISIS-2018-002 / DISIS-2019-001 Study. NPPD also reviewed the proposed interconnection facilities and network upgrades and associated generation interconnection request impacts on the Short Circuit capability of the NPPD system. The NPPD Facility Study includes detailed cost estimates and estimated project schedules for the upgrades identified in the SPP studies.

### **Interconnection Facility Upgrades**

NPPD's Engineering, Asset Management, and Project Management groups have reviewed the interconnection facility upgrades that are required for SPP DISIS-2018-002 / DISIS-2019-001 Generation Interconnection projects. Detailed cost estimates have been prepared for the facility upgrades that were identified in the system impact study for the requests. The prepared cost estimates are study level estimates (+20%/-20%) and assume implementation of standard NPPD construction and procurement practices. The cost estimates for the interconnection facilities are below:

- Etna 345 kV Substation
  - GEN-2018-125
    - 231 MW Wind
  - Build new 345 kV substation on GGS-Sweetwater 345 kV line at an acceptable location near Etna.
  - Project scope would require a new 345 kV substation on the NPPD GGS - Sweetwater 345 kV line at an acceptable location per NPPD's Facility Connection Requirements. The GGS-Sweetwater 345 kV line is critical to the NPPD transmission system and finding an acceptable outage window will be extremely difficult. The GI customer may be responsible for impacts to existing generation resources if the GI related work requires extensive outages to this critical facility. The proposed Generation Interconnection location will have significant impact on the GGS Stability Interface (6006) and LRS/DC stability limitations in western NE. NPPD has documented the GGS Stability Interface study requirements in the NPPD FERC 715 submittal.
  - 60 Month Lead Time

**\$ 37,000,000**



- Pierce County 345 kV Substation
  - GEN-2018-065, GEN-2018-068, GEN-2018-131, GEN-2018-132
    - 322.2 MW Wind (GEN-2018-065, GEN-2018-068)
    - 423 MW Solar (GEN-2018-131, GEN-2018-132)
  - Build new 345 kV substation on the Antelope-Hoskins 345 kV line at an acceptable location near the mid-point of the existing transmission line.
  - Two shared gen-tie lines
    - One gen-tie for GEN-2018-065 & GEN-2018-068
    - One gen-tie for GEN-2018-131 & GEN-2018-132
  - 60 Month Lead Time

**\$ 36,300,000**
  
- Butler County 115 kV Substation
  - GEN-2019-039
    - 174.5 MW Solar
  - Build new 115 kV ring substation at an acceptable location on the Columbus Southeast – Rising City 115 kV line.
  - 36 Month Lead Time

**\$7,800,000**
  
- Olive Creek 115 kV Substation Expansion
  - GEN-2019-041
    - 78 MW Solar
  - Expand substation and add 115 kV bay
  - 36 Month Lead Time

**\$ 2,200,000**
  
- Madison County 345 kV Substation
  - GEN-2019-069, GEN-2019-070, GEN-2019-073, GEN-2018-083
    - 500 MW Wind & Solar
  - Build new 345 kV substation on the Hoskins-Shell Creek 345 kV line at an acceptable location near the mid-point of the existing transmission line
  - One shared gen-tie line
    - One gen-tie for GEN-2019-069, GEN-2019-070, GEN-2019-073, GEN-2018-083
  - 60 Month Lead Time

**\$ 35,100,000**

Preliminary one-line diagrams for each generation interconnection project are in Appendix 2.

## **Generator Interconnection Reactive Compensation Requirements (MVAR)**

The SPP DISIS-2018-002 / DISIS-2019-001 Phase 2 study documented the GI customer reactive compensation requirements for each POI. The following reactive compensation requirements should be included in the generation interconnection agreement as GI customer reactive power requirements to ensure the reliability of the SPP transmission system is maintained following the proposed GI projects.

<b>Gen Number</b>	<b>Fuel Type</b>	<b>MW Amount</b>	<b>Reactive Compensation Requirement (MVAR)</b>	<b>Reactive Compensation Requirement (MVAR) – Per Gen-Tie Line</b>	<b>POI</b>
GEN-2018-125	Wind	231	-2.0	-2.0	Etna 345 kV (GGS-Sweetwater 345 kV)
GEN-2018-065	Wind	19.8	-1.0	-15.6	Pierce County 345 kV (Antelope - Hoskins 345 kV)
GEN-2018-068	Wind	302.4	-14.6		Pierce County 345 kV (Antelope - Hoskins 345 kV)
GEN-2018-131	Solar	221.4	-1.9	-5.1	Pierce County 345 kV (Antelope - Hoskins 345 kV)
GEN-2018-132	Solar	201.6	-3.2		Pierce County 345 kV (Antelope - Hoskins 345 kV)
GEN-2019-041	Solar	78	-0.4	-0.4	Olive Creek 115 kV (Monolith 115 kV)
GEN-2019-039	Solar	174.5	-0.9	-0.9	Butler County 115 kV (Columbus Southeast-Rising City 115kV)
GEN-2018-083	Wind	250	-13.6	-25.1	Madison County 345 kV (Shell Creek-Hoskins 345 kV)
GEN-2019-069	Solar	100	-4.8		Madison County 345 kV (Shell Creek-Hoskins 345 kV)
GEN-2019-070	Solar	50	-1.9		Madison County 345 kV (Shell Creek-Hoskins 345 kV)
GEN-2019-073	Solar	100	-4.8		Madison County 345 kV (Shell Creek-Hoskins 345 kV)

## Network Upgrades

NPPD's Engineering, Asset Management, and Project Management groups have reviewed the network upgrades that are required for SPP DISIS-2018-002 / DISIS-2019-001 Generation Interconnection projects. Detailed cost estimates have been prepared for the facility upgrades that were identified in the system impact study for the requests. The prepared cost estimates are study level estimates (+20%/-20%) and assume implementation of standard NPPD construction and procurement practices. The cost estimates for the network upgrades are below:

- Antelope – Holt County 345 kV Line
  - Build new 345 kV line from Antelope to Holt County including substation terminal additions at both ends.
  - At least 1792 MVA
  - 60 Month Lead Time

**\$ 90,400,000**
  
- Hoskins 345/230 kV Transformer Addition
  - New second Hoskins 345/230 kV transformer and expansion of 230 kV bus at Hoskins would be required. Project requires relocation/replacement of Hoskins T4 to accommodate second 345/230 kV transformer at Hoskins due to substation configuration. The substation site is extremely space limited and it will require unique and complex approach to add another tie transformer at this location. Also, the existing Hoskins T4 unit is 1978 vintage and may not be able to be relocated due to age and condition. Replacement of T4 may be required as part of this project and this cost is not included in estimate at this time. Also, there is a large industrial customer located at this location. This project will impact customer load deliveries and this will need to be taken into account throughout the project to minimize customer interruptions and lost production.
  - At least 417 MVA
  - 60 Month Lead Time

**\$ 45,400,000**
  
- Antelope 345/115 kV Transformer Addition
  - A new second transformer and expansion of Antelope 345/115 kV substation would be required.
  - At least 417 MVA
  - 60 Month Lead Time

**\$ 33,000,000**

- Re-build Columbus Southeast – Butler County (GEN-2019-039) 115 kV line
  - Rebuild with larger conductor would be required as well as terminal upgrades at both ends.
  - At least 240 MVA
  - 36 Month Lead Time

**\$ 3,700,000**
  
- Re-build Rising City – Butler County (GEN-2019-039) 115 kV line
  - Rebuild with larger conductor would be required as well as terminal upgrades at both ends.
  - At least 240 MVA
  - 36 Month Lead Time

**\$ 5,100,000**

The results of DISIS-2018-002 / DISIS-2019-001 documented that several Generation Interconnection requests are contingent on the completion of the following previously allocated required network upgrades:

- Gentleman – Thedford - Holt County (R-Project) and Thedford 345/115 kV Transformer project
- Monolith / Olive Creek 345/115 kV substation
- Columbus East 230/115 kV Transformer upgrade project

Project schedule details will be further discussed in the development of the generator interconnection agreements (GIA) and the milestones associated with the generation interconnection projects.

If the generation interconnection projects proceed to the generation interconnection agreement, then an operating study may need to be performed to fully assess and evaluate the operation of the generation facility and network upgrades in accordance with NERC Standards. The operating study requirement will be included in the generation interconnection agreement with NPPD. If any generation interconnection projects are identified to have significant impact on the GGS Stability Interface (Flowgate #6006) and LRS/DC stability limitations in western NE, then the operating study will need to take these issues into account. The operating study may also need to evaluate the reactive power control requirements and associated equipment necessary to meet operational voltage requirements at the requested point of interconnection.

## **Short Circuit Study**

NPPD's Engineering group has reviewed the short circuit impacts of the SPP DISIS-2018-002 / DISIS-2019-001 Generation Interconnection projects and associated network upgrades interconnected to the NPPD transmission system. The result of this study is documented in Appendix 1. The short circuit study identified a breaker at the NPPD Columbus Hydro 115 kV substation that needs replaced (Columbus 115 – 1126). The details of this breaker replacement are listed below. This breaker replacement network upgrade project should be included in the Generation Interconnection agreements associated with the DISIS-2018-002 / DISIS-2019-001.

- Replace Columbus Hydro 115 kV breaker
  - Replace Columbus Hydro 115 kV breaker 1126 with higher interrupting rating breaker.
  - At least 40 KA
  - 36 Month Lead Time

**\$ 1,000,000**

## **Appendix 1**

**NPPD Short Circuit Study Report**

**DISIS-2018-002 / DISIS-2019-001**



# Short Circuit Study

## Model Development

### Computer Programs

The Aspen OneLiner software program was utilized to perform short circuit simulations and studies on the transmission system. Where elements were added to the short-circuit model, best estimates for impedance parameters were used based on available data and typical modeling practices. Short-circuit calculation options used were as follows:

- Flat voltage profile with  $V(\text{pu}) = 1.0$
- Generator Impedance = Subtransient
- Ignore loads, transmission line  $G+jB$ , and shunts with positive sequence values

OneLiner was used to calculate three-phase (3PH) and single-line-to-ground (SLG) system-intact bus fault currents for all system buses associated with interrupting devices being evaluated in this study. For devices that the full bus fault current approached or exceeded the device's interrupting rating, more detailed fault calculations were done, calculating the maximum phase current through the breaker for close-in faults, close-in faults with the remote end open, and bus faults with all other branches to the bus open. The maximum phase current of these faults was recorded. For comparison with the breaker interrupting ratings, maximum phase current was multiplied by a factor of 1.05 to account for the possibility of the system operating at up to the maximum normal operating voltage of 1.05 per-unit.

### Base System Model Additions (“Base Case”)

The base system model used by the transmission system protection department as of December 30, 2024 was used as the starting point for the short-circuit model used for this study. The base system model included all projects that were in-service at the time the model was copied. All Nebraska-area generation in the short-circuit model was enabled in order to provide maximum short-circuit current. For the study base case, planned system upgrades in the area of the studied projects and prior-queued large generator interconnections expected to be in-service prior to the projects being studied were added to the base case model. Table 1 lists the prior-queued large generator interconnections that were added to the base model for this study.



**Table 1: Prior Queued Large Generator Interconnections**

<b>Queue Designation</b>	<b>Proposed POI</b>	<b>Capacity (MW)</b>
GEN-2013-002	Hallam 115kV / Panama WF to Olive Creek	50.6
GEN-2013-019	Hallam 115kV / Panama WF to Olive Creek	73.6
GEN-2017-105	OPPD Tekamah - Raun 161kV	75
GEN-2017-144	Holt County 345kV Substation (Expand substation)	200
GEN-2017-181	Tobias 345kV Substation (Expand substation)	300
GEN-2017-182	Tobias 345kV Substation (Expand substation)	128
GEN-2017-201	Turtle Creek 345kV connect at Sholes WF	250
GEN-2017-210	McCool 345kV Substation (Expand substation)	310
GEN-2017-234	Greeley 115kV Substation (New substation)	115
GEN-2018-012	Antelope 345kV Substation (Expand substation)	74.1
GEN-2018-060	Macon 345kV Substation (Expand substation)	50

In addition to the prior-queued large generator interconnections, planned system upgrades in the area of the studied projects were added to the base model. These include:

- The planned 345kV line from GGS – Thedford – Holt County “RPLAN” was included with a 345kV/115kV tie transformer at Thedford 115 kV
- New Olive Creek sub addition near Mark Moore/Sheldon
- 115kV L1382 Kearney Techone to Tower
- 115kV L1324 Scottsbluff to Victory Hill
- Upgrade of the Columbus East T3 to 336MVA
- Stanton North expansion for a new 100MVA load-serving transformer, future 115kV line Stanton North to Norfolk, Hoskins T1 replaced with a 336MVA
- Upgrade of Mark Moore T1 replacement with a 417MVA

### **Model Additions for Projects Being Studied (“Study Case”)**

The base-case study model was modified to include the new generation interconnections being considered in this study as well as the system upgrades identified to accommodate this additional generation. Table 2 lists the large generator interconnections that were added to the study-case model for this study.

**Table 2: Large Generator Interconnections Added to Study Case**

<b>Queue Designation</b>	<b>Proposed POI</b>	<b>Capacity (MW)</b>
GEN-2018-065	Pierce County 345kV Substation (New substation)	19.8
GEN-2018-068	Pierce County 345kV Substation (New substation)	302.4
GEN-2018-125	new Etna 345kV Substation (New substation)	231
GEN-2018-131	Pierce County 345kV Substation (New substation)	221.4
GEN-2018-132	Pierce County 345kV Substation (New substation)	201.6
GEN-2019-039	Butler County 115kV Substation (New substation)	174.5
GEN-2019-041	Olive Creek 115kV Substation (Expand substation)	78
GEN-2019-069,-070,-073,2018-083	Madison 345kV Substation (New substation)	500

In addition to the DISIS-2018-002, DISIS-2019-001 generator interconnections, network system upgrades in the area of the studied projects were added to the base model. These include:

- New 345kV line from Antelope to Holt County
- Addition at Hoskins of a 345kV/230kV transformer at 417MVA
- Addition at Antelope of a 345kV/115kV transformer at 417MVA
- Rebuild of L1153B Columbus SE to new collector sub for G19-39-TAP (Butler County) to Rising City

## **Study Methodology**

Circuit breaker, circuit switcher, and fuse ratings were identified by querying NPPD's SAP equipment database and extracting equipment data including short-circuit ratings. Breaker ratings given on an asymmetrical (total current) basis were converted to symmetrical current ratings using an assumed maximum system operating voltage of 1.05 per unit.

The calculated short-circuit current at the equipment bus was extracted from the short-circuit results from Aspen OneLiner and compared against the interrupting device interrupting rating. It is recommended that all equipment be replaced if it is found to be at or above 95% of its interrupting rating and seeing an increase of 1% or more in its interrupting duty as a result of the studied projects.

## Results

The following devices were found to be above 95% of their interrupting rating due to the addition of the projects considered in this study and are recommended for replacement.

<b>Location – Breaker</b>	<b>Manuf.</b>	<b>Model Number</b>	<b>Interrupting Rating</b>	<b>Max Expected Interrupting (A)</b>	<b>Max Current (% of Rating)</b>	<b>Relative Change (%)</b>
<b>COLUMBUS 115 - 1126</b>	GE	FK-115-5000	19922	19596	103.3%	11.2%

## **Appendix 2**

### **Generation Interconnection Facilities One-Line Diagrams**



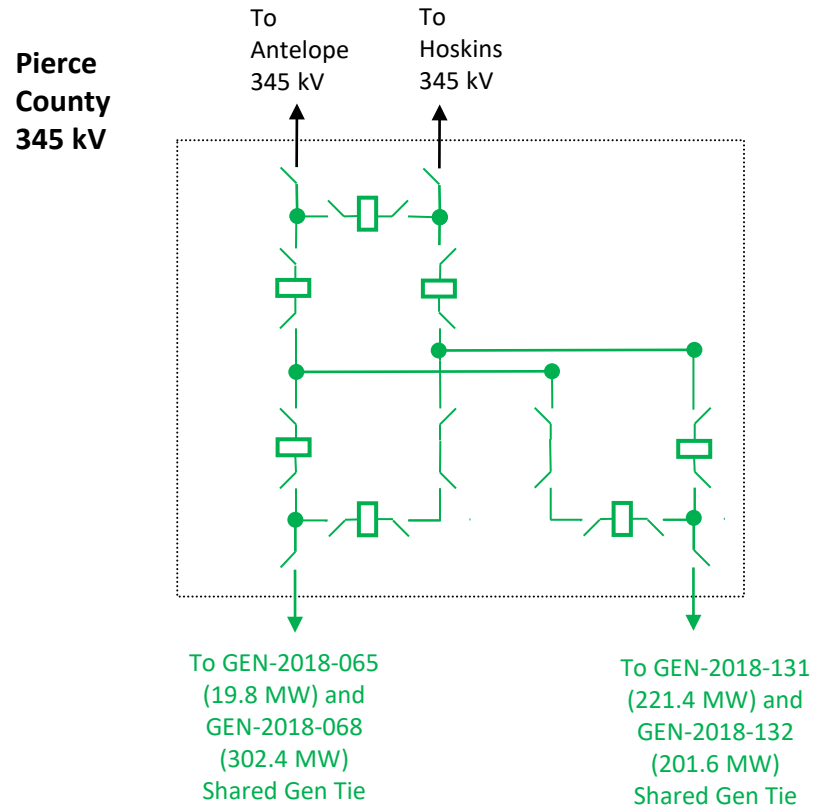

- DISIS-2018-002 & DISIS-2019-001 Interconnection Facilities for GEN-2018-065/GEN-2018-068/GEN-2018-131/GEN-2018-132

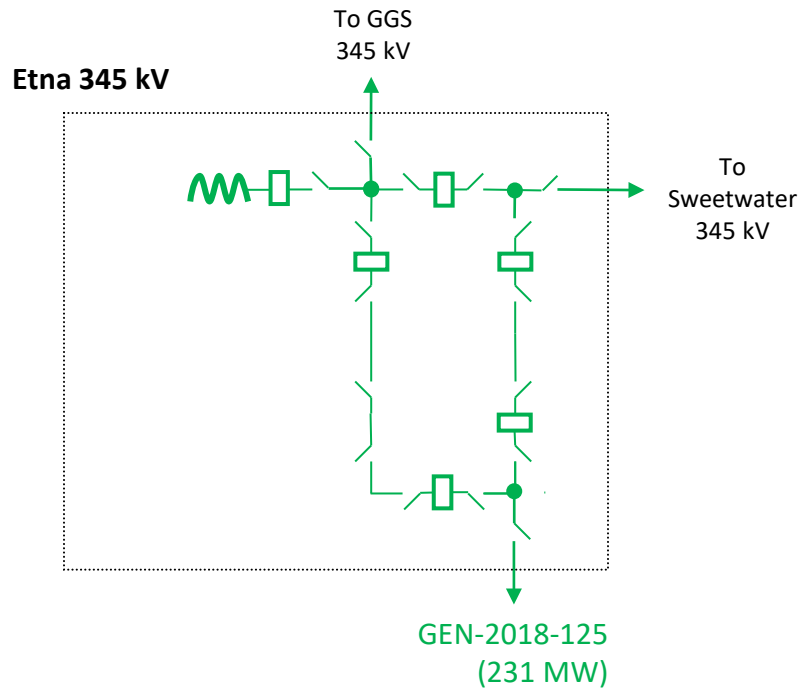

- DISIS-2018-002 and DISIS-2019-001 Interconnection Facilities for GEN-2018-125

### Butler County 115 kV

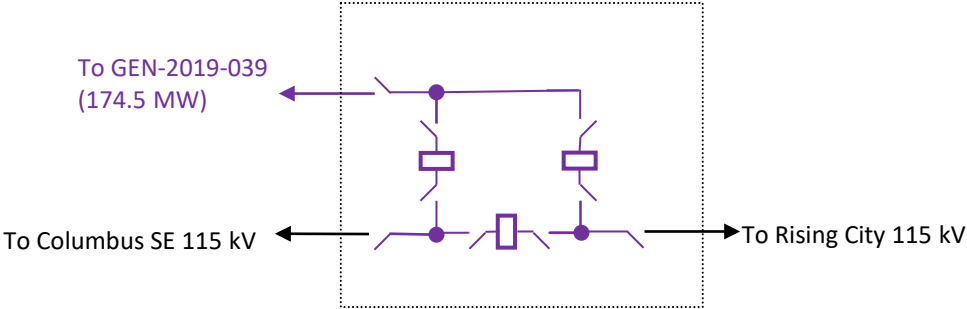

- DISIS-2018-002 and DISIS-2019-001 Interconnection Facilities for GEN-2019-039



# Olive Creek 115 kV Substation

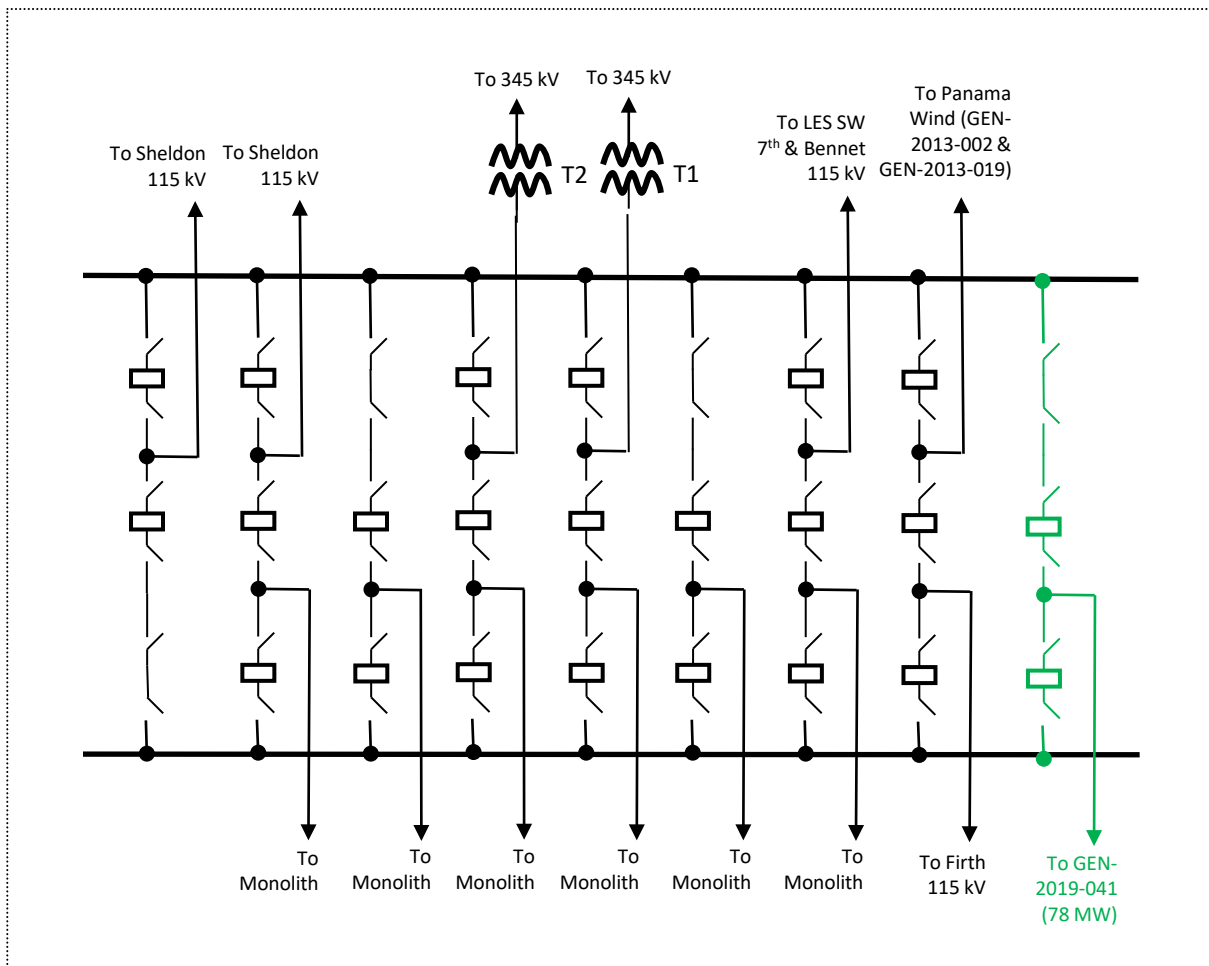

- DISIS-2018-002 and DISIS-2019-001 Interconnection Facilities for GEN-2019-041

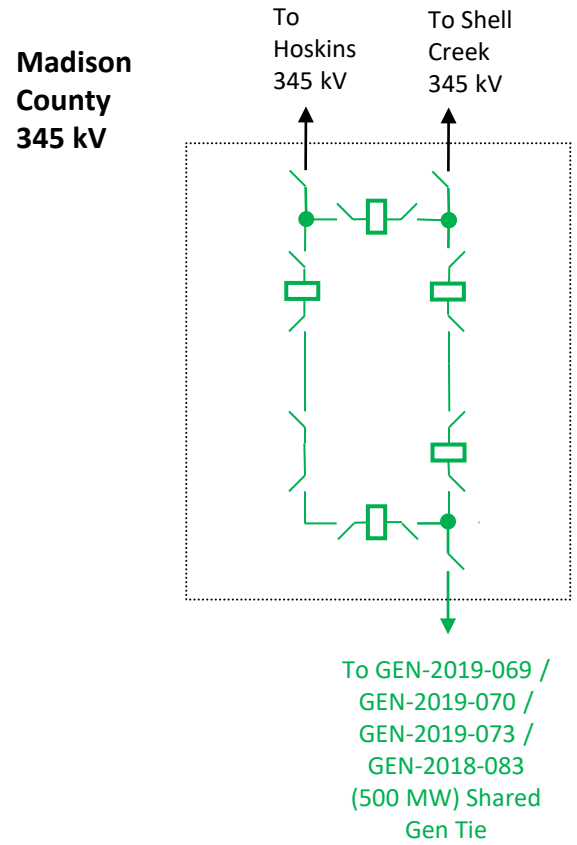

- DISIS-2018-002 & DISIS-2019-001 Interconnection Facilities for GEN-2019-069/GEN-2019-070/GEN-2019-073/GEN-2018-083